



IXP20 CONTROLLER

ImproX IXP20 Controller INSTALLATION MANUAL

SPECIFICATIONS

Working Environment

Plastic Housing..... Designed to work in an indoor (dry) environment similar to IP40. The Controller is not sealed against water.

Power

Input Voltage..... 10 V DC to 30 V DC, polarity sensitive.

Power Requirements (ISC910) **Current (mA)** **Power (W)**

Input Voltage 12 V DC with no Antennas attached 90 1.08

Input Voltage 24 V DC with no Antennas attached 50 1.20

Input Voltage 12 V DC with Antennas attached 100 1.20

Input Voltage 24 V DC with Antennas attached 60 1.44

Power Requirements (ISC911)

Input Voltage 12 V DC with no Antennas attached 140 1.68

Input Voltage 24 V DC with no Antennas attached 65 1.56

Input Voltage 12 V DC with Antennas attached 150 1.8

Input Voltage 24 V DC with Antennas attached 75 1.8

Relay Power Requirements An additional ~0.4 W per Relay in use.

Real Time Clock (RTC) Backup Battery

Battery Type..... 1 x 3 V, CR2032, Lithium cell Battery.

**Real Time Clock (RTC) Backup
Battery (Continued)**

Battery Life 1 Year with power OFF,
5 years with power ON,
5 years storage with Battery Tab in place.

Controller Communication

Ethernet Port Standard Ethernet RJ45 connector.
10/100 Base T, half or full duplex.

Terminal Communication

RS485 Terminal Port

Electrical Interface RS485.
Baud Rate 38 400.
Data Format 8 data bits, no parity, 1 stop bit.
Communications Protocol ImproX Secure Communications Protocol.
Line Termination (RS485) Provision is made for line termination.

Reader Options

Antenna Reader Ports 2 Fully functional Antenna Reader Ports.

Relays

Relay Output 2 Independent, single-pole, double-throw
(SPDT) Relays, each with NO, COM and NC
contacts.
Relay Contact Ratings 10 A at 28 V DC,
5 A at 220 V AC,
12 A at 120 V AC.
Operations 100 000 Minimum.

Digital Inputs

Type 4 Dry-contact Digital Inputs.
Detection Resistance Range < 2 kOhm.
Protection Range +15 V continuous.

Blank Space

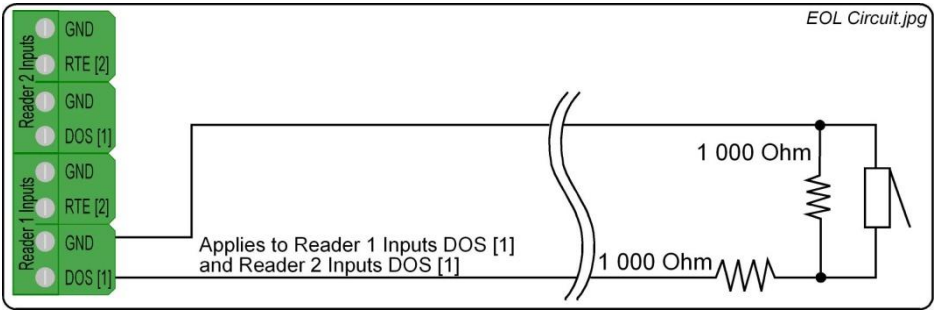

Figure 1: End of Line (EOL) Sensing Circuit

NOTE: *End of Line (EOL) Sensing enables the Controller to raise an alarm when somebody tampers with the circuit (that is, cutting or shorting the wires) between either Reader 1 Inputs DOS [1] or Reader 2 Inputs DOS [1] and GROUND (GND). In other words the Controller distinguishes between tampering on the circuit, and the door being in an actual 'Normally Open' state.*

By placing Resistors into the circuit between either Reader 1 Inputs DOS [1] or Reader 2 Inputs DOS [1] and GROUND (GND), the Controller's Digital Input monitors a constant resistance through the circuit. When the circuit is tampered with, the Resistors are bypassed; the Controller detects the resistance change raising an alarm.

Door Lock

Type 2 Dry-contact inputs.
 Protection Range +15 V continuous.

General

Antenna Frequency 125 kHz.
 Antenna Read Capability Slim Tags Omega Tags, Philips HITAG™ 1, Philips HITAG™ 2 and HID 125 kHz Tags.

CAUTION: **The IXP20 System does not support the use of HID 1346 Proxkey II Tags.**

NOTE: *HID is a registered trademark of HID Global Corporation (an ASSA ABLOY Group Brand).*

Controller Diagnostic Indicators

Buzzer
 Volume and Tone Single tone, with a 3-step adjustable volume.
 Display (ISC911 Only)
 Type Thin Film Transistor Liquid Crystal Display (TFT-LCD).
 Resolution..... 240 x 320 Pixels.

Display (Continued)

Colour	65 K Colour Screen.
Back-lighting	Permanently on.
Status LED	
Power On.....	Continuous Red.
Upgrade Mode.....	Flashing Red (Steady).
Incoming RS485 Data	Flashing Green LED.
Outgoing RS485 Data	Flashing Red LED.
Digital Inputs (1-4).....	Continuous Green on detected contact closure.
Relays (1 and 2).....	Continuous Red on activation of the Relay.
Enet Act (Ethernet Activity)	Flashing Red LED.
Enet Spd (Ethernet Speed)	Continuous Red for 100 Mbps (Default) Off for 10 Mbps.
Enet Lnk (Ethernet Link)	Continuous Red on connection to network.

INSTALLATION INFORMATION

Accessories

CAUTION: The IXP20 Controller needs a standard Ethernet cable to connect to a PC. We do NOT however supply this cable with the Controller's accessories.

Find the following when unpacking the IXP20 Controller:

- Either an ImproX IXP20 Twin Antenna Controller with Web Interface (ISC910) supplied in a Black ABS Plastic housing. The housing consists of a Front Cover Assembly and a Mounting Plate. The Front Cover and Mounting Plate are held together with two Combi Screws (M4 x 10 mm) at the bottom of the housing.
- There are also two spare Combi Screws (M4 x 10 mm).
- Or, an ImproX IXP20 Twin Antenna Controller with Touch Screen (ISC911) supplied in a Black ABS Plastic housing. The housing consists of a Front Cover Assembly and a Mounting Plate. The Front Cover and Mounting Plate are held together with two Combi Screws (M4 x 10 mm) at the bottom of the housing.
- There are also two spare Combi Screws (M4 x 10 mm).

CAUTION: DO NOT use the Metal-oxide Varistors (25 Vrms, 500 A, 77 V max clamping) with mains power applications.

- Three Metal-Oxide Varistors, 25 Vrms, 500 A, 77 V max clamping.
- A 3 V, CR2032, Lithium cell Battery.

NOTE: The 3 V, CR2032 Lithium cell Battery is partially installed in all models of the IXP20 Controller.

- An extra Fixed Address Label.

General

Remember the following when installing the IXP20 Controller:

Communications Distance

The RS485 communications distance between the first IXP20 Controller and the LAST ImproX unit in a cable run, MUST NOT exceed 1 km (1 090 yd). Achieve this by using good quality screened twisted 2-pair cable, with the screen EARTHED at one end.

Jumper Links

Long transmission lines or multiple “star” connections, may cause communication problems. Placing a Jumper Link across the jumper (See Figure 3 for position) in the LAST UNIT AT THE END OF THE CABLE RUN should solve the problem.

Antenna Reader Distance

The ideal cable distance between the IXP20 Controller and a Non-keypad Antenna Reader ranges between 2 m to 25 m (7 ft to 82 ft). The ideal cable distance between the IXP20 Controller and a Keypad Antenna Reader ranges between 2 m to 16 m (7 ft to 53 ft). Optimal performance is not guaranteed outside of these ranges. Achieve optimal performance using a good quality shielded multi-strand 3-pair twisted cable. The cable individual conductor cross-sectional area should not be less than 0.2 mm² (0.0003 in²).

Ensure that your cable specifications are similar to the following:

- Conductor Resistance: < 2 ohms.
- Capacitance, Core to Earth: < 160 pF/m.
- Capacitance, Core to Core: < 100 pF/m.

Distance between Antenna Readers from the SAME Controller

To avoid mutual interference, install the Antenna Readers alongside each other at least 150 mm (6 in) apart.

Distance between Antenna Readers from DIFFERENT Controllers

To avoid mutual interference, install the Antenna Readers alongside each other at least 500 mm (20 in) apart.

NOTE: IXP20 Controllers (ISC910) can be mounted alongside each other. To avoid mutual interference, install the Touch Screen IXP20 Controllers (ISC911) at least 500 mm (20 in) apart.

EARTH Connection

Connect the IXP20 Controller to a good EARTH point. Using the RS485 Port, connect the EARTH Lead to the ‘ETH’ Terminal. Mains EARTH can be used, but electrical noise may exist.

Blank Space

Arc Suppression

Snubber devices are recommended for EMF Flyback and Arc Suppression when driving an inductive load with the Relay, see Figure 2.

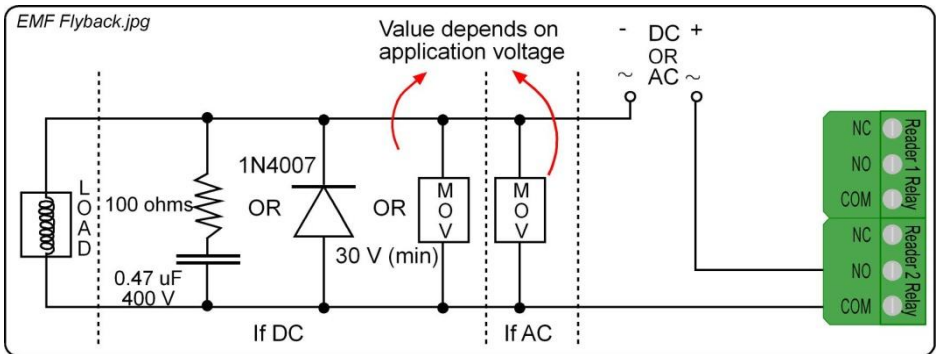

Figure 2: EMF Flyback and Arc Suppression

Installing the Real Time Clock (RTC) Backup Battery

CAUTION: Remove the Battery Tab for the Real Time Clock from the Battery Holder **IMMEDIATELY BEFORE** powering up the IXP20 Controller. **DO NOT** remove the Battery Tab after applying power to the IXP20.

First Time Use

1. Ensure that power is NOT applied to the Controller.
2. Locate the removable Battery Tab at the bottom of the Controller's housing.
3. Pull the removable Battery Tab out of the Battery Holder.
4. Immediately apply power to the Controller.

Replacement

NOTE: Because of the delicacy of this procedure, we recommend you contact your distributor before trying to replace the Battery.

Mounting the IXP20 Controller

CAUTION: Make certain that you mount the Controller on a vibration-free surface.

NOTE: The IXP20 Controller can be mounted onto virtually any surface including metal.

Select the mounting position of the IXP20 Controller, considering accessibility, routing of wires and visibility of the Thin Film Transistor Liquid Crystal Display (TFT-LCD) and accessibility of the Keypad.

Secure the enclosure to the mounting surface, using four suitable screws and wall plugs, nuts and bolts or rivets.

DIP-switch Settings

NOTE: Once the DIP-switch settings are modified reset the IXP20 Controller to acknowledge the new settings.

Door Lock Select DIP-switch Settings





DIP-switch Position	Connections
0  DIP-switch 0 shows switches 2, 3 and 4 in the OFF position	Reserved.
1 	Reserved.
2 	Reserved.
3 	Reserved.
4 	Reserved.
5 	Returns Controller to Factory Default Settings. NOTE: Return Switch 1 to the OFF position to resume normal operation.

Table 1: Door Lock Select DIP-switch Settings

Blank Space

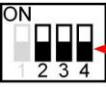
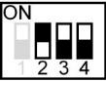
ELECTRICAL CONNECTIONS

Key Component Positions

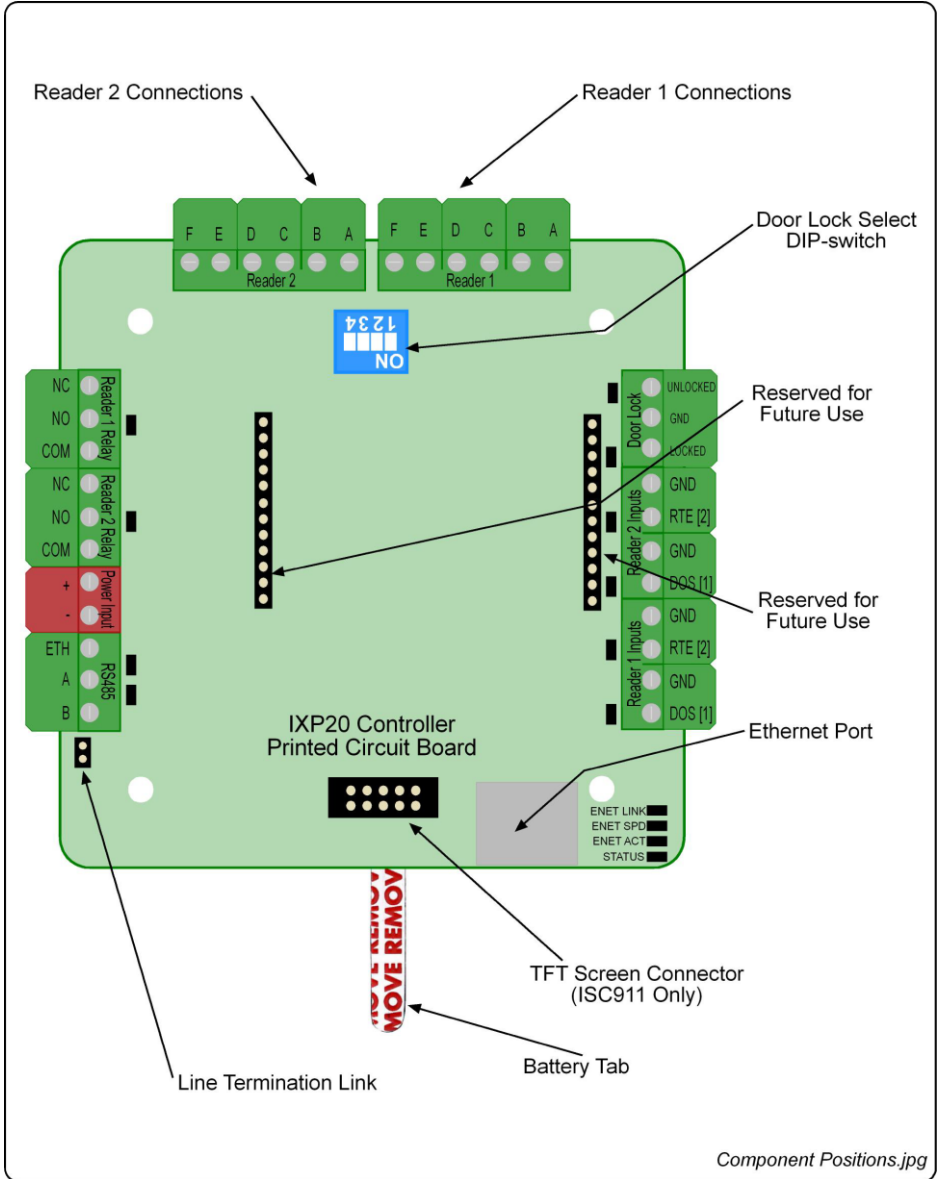

Figure 3: Key Component Positions

Connecting the IXP20 Controller

Figure 4 shows a detailed electrical connection diagram for the IXP20 Controller.

NOTE: The ideal cable distance between the IXP20 Controller and its Non-keypad Antenna Reader ranges between 2 m to 25 m (7 ft to 82 ft). The ideal cable distance between the IXP20 Controller and its Keypad Antenna Reader ranges between 2 m to 16 m (7 ft to 53 ft).

NOTE: Connection details remain the same for the majority of the ImproX Antenna Readers. Note, however that the ImproX MMA only uses connections C, D, E and F.

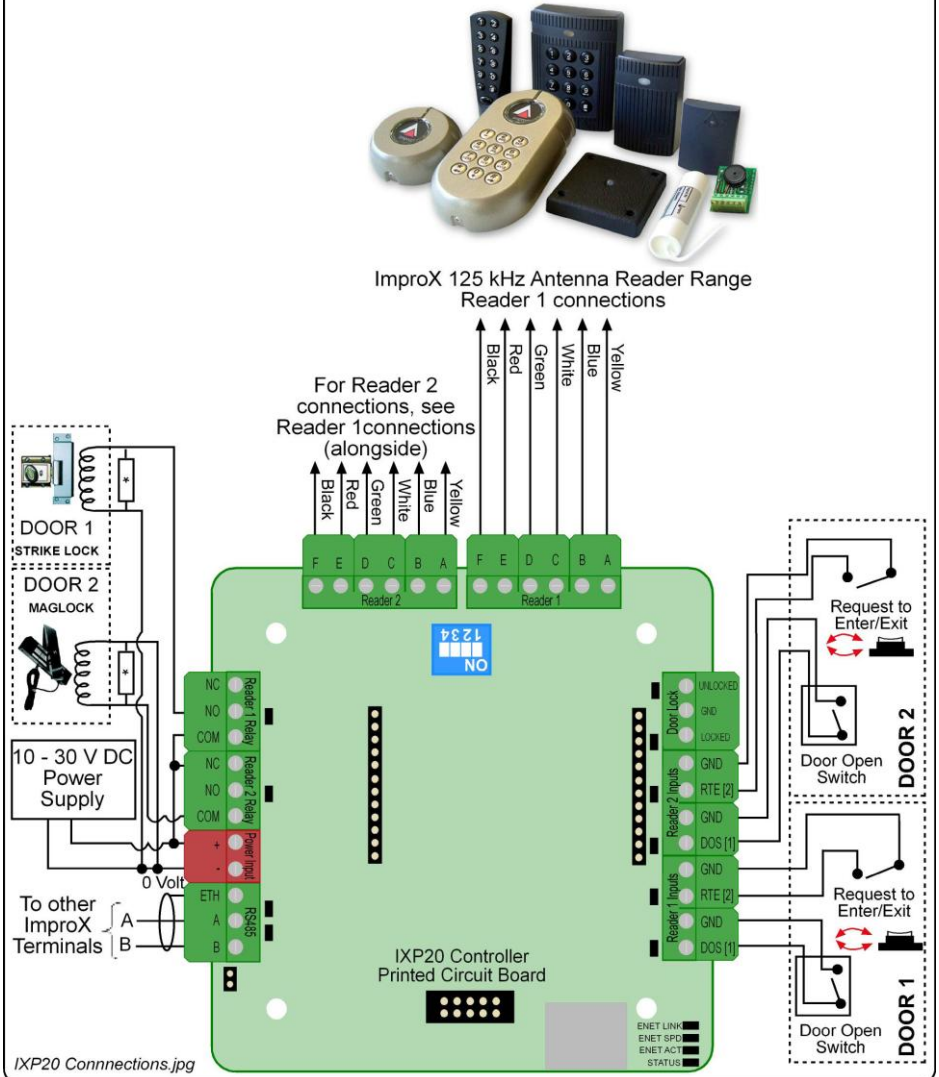

Figure 4: Typical IXP20 Controller Electrical Connections

ADVANCED SETTINGS

Restoring Factory Default Settings

CAUTION: The procedures below are Controller specific. Ensure that you follow the correct procedure for your model Controller. Failure to do so results in loss of the Database.



Restore the Controller's factory default settings as follows:

ISC910

1. Remove the Controller's Front Cover Assembly.
2. Set the Door Lock Select DIP-switch Switch 1 to the ON position (see Table 1, row 5 for details).
3. Reset the Controller by removing and then reapplying the power source.
4. With the Controller running, set the Door Lock Select DIP-switch Switch 1 back to the OFF position (see Table 1, row 5 for details).
5. Reattach the Controller's Front Cover Assembly.

ISC911

CAUTION: Ensure that you return Switch 1 of the Door Lock Select DIP-switch to the OFF position. Failure to do so automatically clears the System Database on the next restart.

1. Remove the Controller's Front Cover Assembly.
2. With power applied to the Controller, toggle switch 1 of the Door Lock Select DIP-switch ON and then OFF.
3. Complete the Action textbox, by clicking the  button and selecting from the following:
 - **No Change**—maintains user settings.
 - **Reset Admin Password**—restores the administrator password to factory default (12345) without resetting the System Database.
 - **Reset System Database**—clears the Database, restoring it to factory default settings.
4. Click the  button.
5. Click the  button.
6. Reattach the Controller's Front Cover Assembly.

UNIT ADDRESS INFORMATION

Fixed Address

Once the IXP20 Controller is installed, sketch a rough site plan. Attach the loose (additional Fixed Address Label packaged with the Controller) Fixed Address Label in the position of the Controller on the sketched site plan. When the system installation is complete and all the units are represented on the site plan by their Fixed Address Labels, file the site plan for future reference.

The Fixed Address Label included with the Controller is the Fixed Address for the Controller only. In addition to the Controller Fixed Address, the IXP20 Controller reports up to two Terminal Fixed Addresses.

- Controller's Fixed Address: 6E XX XX XX.
- Reader 1's Fixed Address: 6F XX XX XX.
- Reader 2's Fixed Address: 70 XX XX XX.

NOTE: *Where additional Terminals connect to the Controller, extra Fixed Addresses for the respective Terminals appear during the Software's Auto-ID process.*

MAC Address

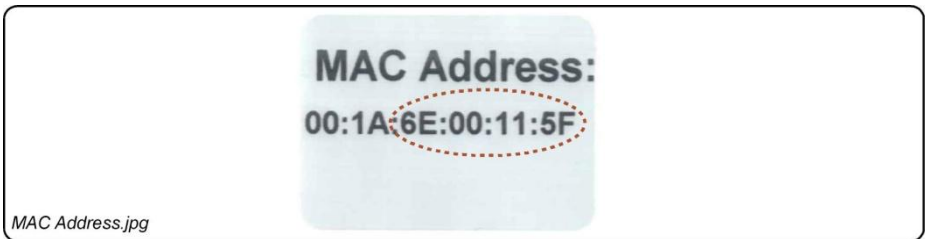

Figure 5: Sample MAC Address Label

Each IXP20 Controller is supplied with a separate MAC Address Label, much like the one shown in Figure 5, which uniquely identifies each Controller.

Attach the extra loose MAC Address Label, alongside the Fixed Address Label, to the Unit Location Chart enclosed (or your sketched site plan).

IP Address

NOTE: *All ImproX IXP20 Controllers have the same IP Address (192.168.100.1). In the absence of a DHCP server, plug each Controller into the network individually and set the static IP Address.*

Unit Location Chart

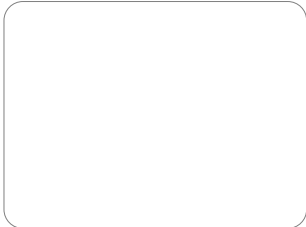
Fixed Address Label	Unique Location Description
	

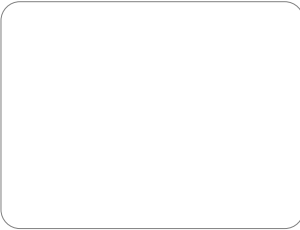
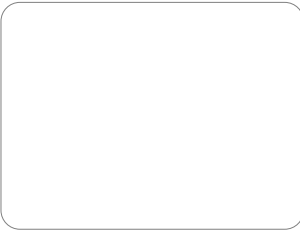
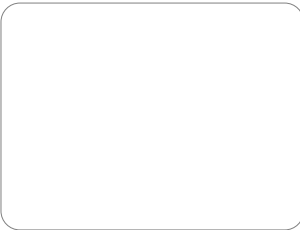
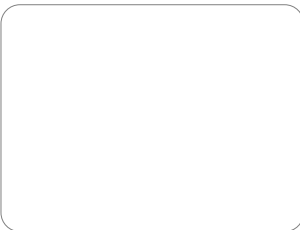
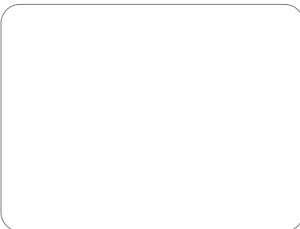
Fixed Address Label	Unique Location Description
	
	
	
	
	

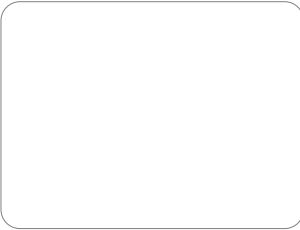
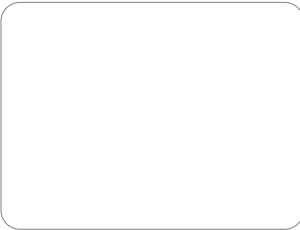
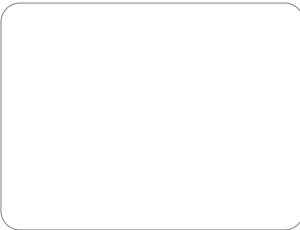
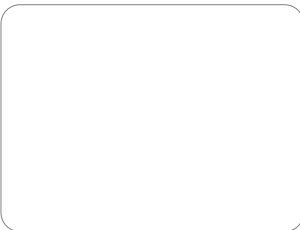
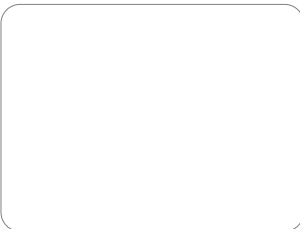
Fixed Address Label	Unique Location Description
	
	
	
	
	

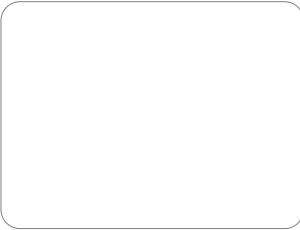
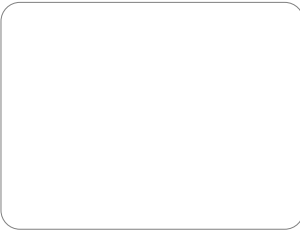
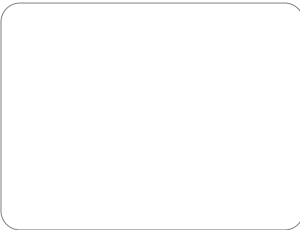
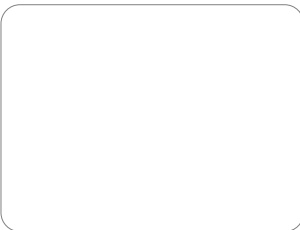
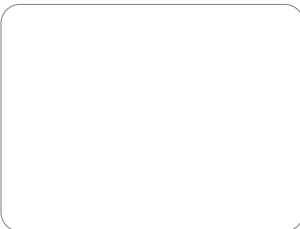
Fixed Address Label	Unique Location Description
	
	
	
	
	

Fixed Address Label	Unique Location Description
	
	

Table 2: Unit Location Chart

GUARANTEE OR WARRANTY

CAUTION: We reserve the right to nullify the products guarantee or warranty where you have not properly installed the Metal-oxide Varistors.

This product conforms to our Guarantee or Warranty details placed on our Web Site, to read further please go to www.impro.net.

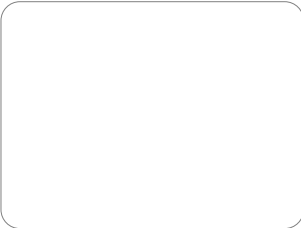
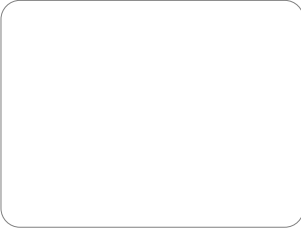
USER NOTES



This manual is applicable to the ImproX IXP20 Controller, ISC910-1-0-GB-03 and ISC911-5-0-GB-03.

(The last two digits of the Impro stock code indicate the issue status of the product).

ISC303-0-0-GB-06	Issue 07	Jul 2011	IXP20\Controller\English Manuals\LATEST ISSUE\ IXP20iTT-in-sm-en-07.docx
------------------	----------	----------	---