

DH-HAP120-V

Hi-fidelity Pickup



Features

- Easy to install;
- IP66 Waterproof monitor head, using waterproof MIC;
- Built-in noise filter chip, high voice clarity;
- Spiral design, hidden installation, conveniently fixed to the equipment panel, uneasy damage, convenient application;
- 8KV Air contact ESD, built-in Lightning Protection, power polarity reverse protection and power protection module.

Technical Specifications

Model	DH-HAP120-V
General	
Scope	5m
Frequency Response	20Hz~20kHz
Sensitivity(re 0dB=1V/Pa@1kHz)	-43dB
Default Gain	44dB
Gain Adjustment Range	Non adjustment
SNR(Re 94dBSPL=1Pa@1KHz)	58dB(A)
Dynamic Range	74dB(A)
Directional Characteristic	Omni-irectional
Max. Sustainable Sound Pressure	110dB SPL(1kHz, THD≤1%)
Output Impedance	100Ω(non-equilibrium)
Output Signal Amplitude	2.5Vpp/101dBSPL
Working Voltage	DC 12V
Working Current	60mA
Working Temperature	-30°C ~ +70°C (-22°F ~ +158°F)
Color	Silver
Outer Shell	Aluminum
Dimension	φ35mmx50mm (φ1.38"x1.97")
Weight	60g (0.13lb)
Carried Standard	CE/FCC

Interface information

- RCA female connector
- DC Power connector

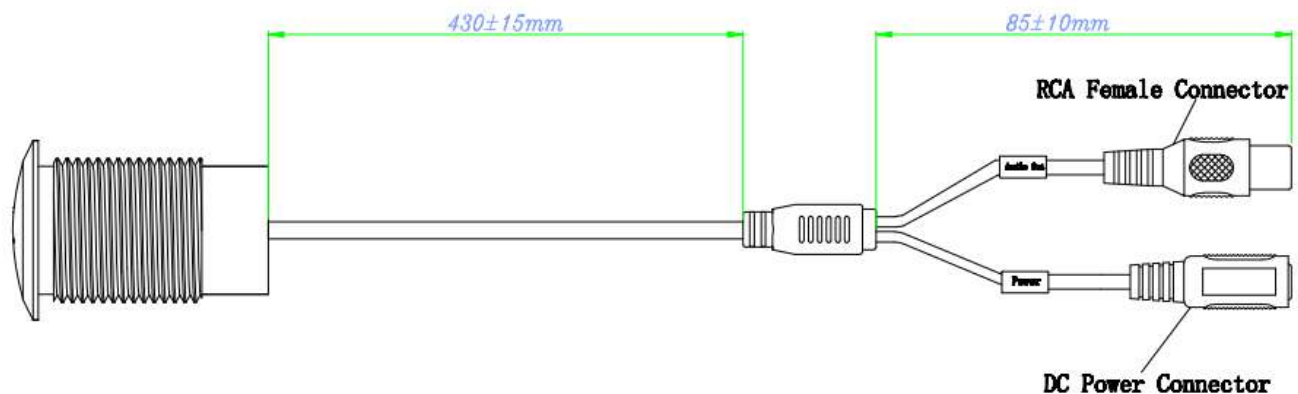

Dimensions (mm/inch)

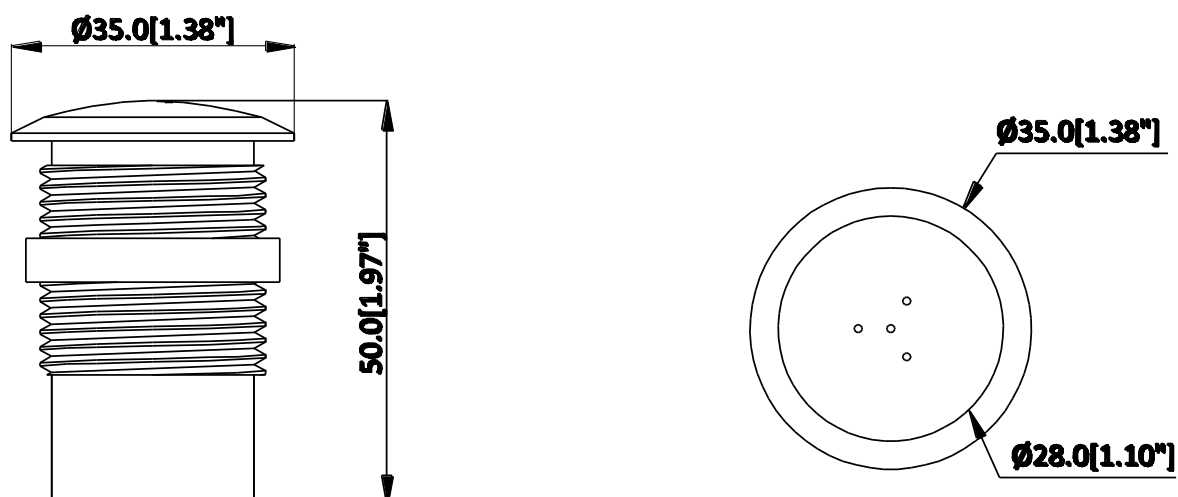

Application scenarios

- Suitable for interrogation, sentry box, doorman, outdoor alarm box and other places.

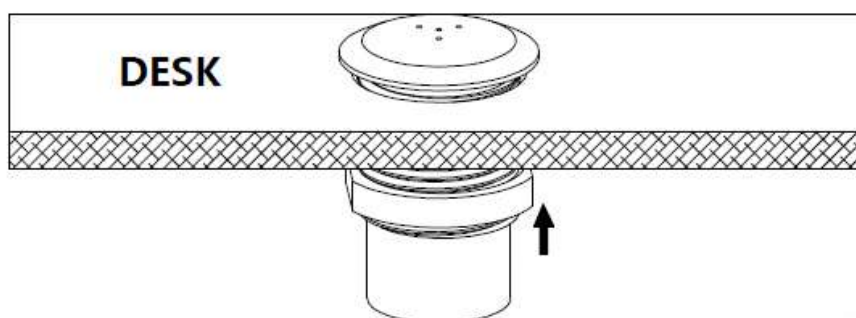

Package Information

- Hi-fidelity Pickup *1
- M4 screw&anchor *3
- User manual *1